



SUBJECT: RADIATOR COOLING FAN MOTOR
VEHICLES: 365 GT4 2+2, 365 GT 2+2, 365 GTB4 & 365 GTC 4

PARTS INFORMATION:

A new Lucas cooling fan motor P.N. 107429 is now available since the previously used Marelli fan motor P.N. 102029 is no longer in production. The new motor can be adapted to the existing fitting through a proper clamp (see Fig. B.). It is recommended to position the new fan in the same place as the old one.

<u>Old Part No.</u>	<u>Description</u>	<u>New Part No.</u>
102029	Electric Motor	107429
105819	Fan	105820
	Clamp	108641
	Cable (200mm long)	Manufacture
	Cable (200mm long)	Manufacture

NOTE: This Bulletin updates the applicable Spare Parts Catalogue.

FIG. A
 SOLUZIONE ESISTENTE
 ORIGINAL FITTING

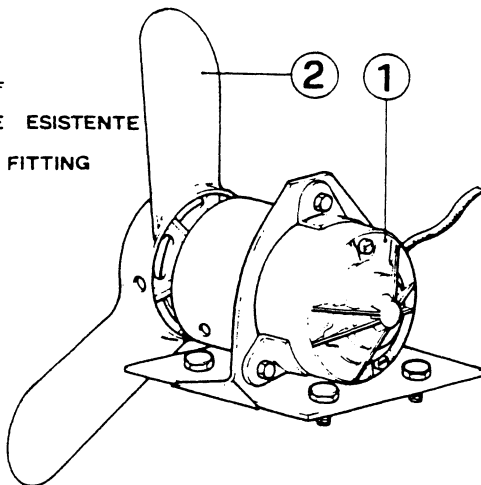

FIG. B
 NUOVA SOLUZIONE
 NEW MODIFIED FITTING

