



Service Bulletin

SB 15-2
8/10/87

PRODUCTION CHANGE /
SCHEDA INTRODUZIONE VARIANTE

SUBJECT / OGGETTO: AIR PUMP
VEHICLES / VETTURE TIPO: TESTAROSSA (US & JAPAN VERSIONS)

	MODELS/MODELLI	TR						
	AREA	USA-J						
Starting from: Inizio modifica dal:	chassis/ telaio no.	69651						
	engine/motore no.	571						
	gearbox/cambio no.							

Description / Descrizione:

The fastening of the electro-magnetic clutch to the air pump has been modified. The new air pump/clutch assembly is interchangeable with the replaced assembly, but the individual parts are not interchangeable.

Reasons / Motivo:

Production change.

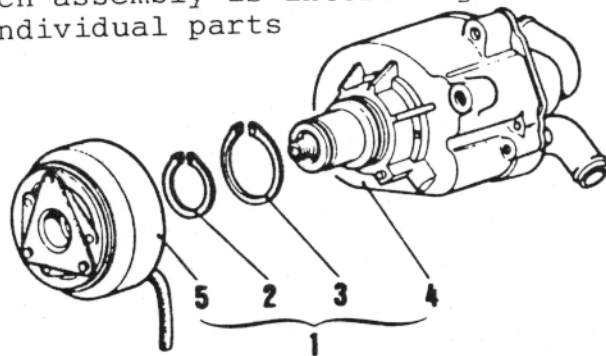

OLD PART NO. / PARTICOLARI SOSTITUITI			NEW PART NO. / NUOVI PARTICOLARI		
Fig.	P. Number Disegno	Description / Denominazione	Fig. Rif.	P. Number Disegno	Description / Nuovi Particolari
			1	134082	Air pump/clutch assy.
			2	134079	Circlip
			3	134078	Circlip
4	125244	Air Pump	4	129519	Air Pump
5	125245	Electro-Mag Clutch	5	130443	Electro-Mag Clutch

Spare parts procedures / Norme per ricambi

For the earlier type Testarossa vehicles, after exhaustion of the replaced parts, it will become necessary to install the new assembly.

Reference spare parts catalogue / Riferimento cat. ricambi